

BriteWay™

Canopies + Walkways



Clearspan Canopies

Pre-engineered canopies + walkways

Our BriteWay™ clearspan canopy is a standardized system that has been pre-engineered based on specific design criteria to ensure lasting performance. The innovative clearspan design eliminates the need for cross-bracing, which opens up the space below the canopy structure, creating a more comfortable and pleasant environment for pedestrians. These canopies not only provide shelter, but also allow diffuse natural light to pass through, resulting in a more vibrant walkway.

Benefits include...

- Design flexibility – a wide range of standard and custom finish colors, a broad selection of glazing colors, and a maximum canopy width of up to 20 ft.
- The rust-free aluminum structure offers excellent durability and system longevity
- KLA is able to provide a single-source solution, supplying everything from the ground up
- Components are shipped fully fabricated and ready to be assembled to ensure superior quality control and simplify the installation process
- No on-site cutting, welding or painting is necessary, which reduces labor time and installation costs
- Optional gutters and downspouts can be provided by Kingspan Light + Air | CPI Daylighting
- Optional Kynar® finish is available with up to a 20-year warranty
- An economical solution that fits your budget

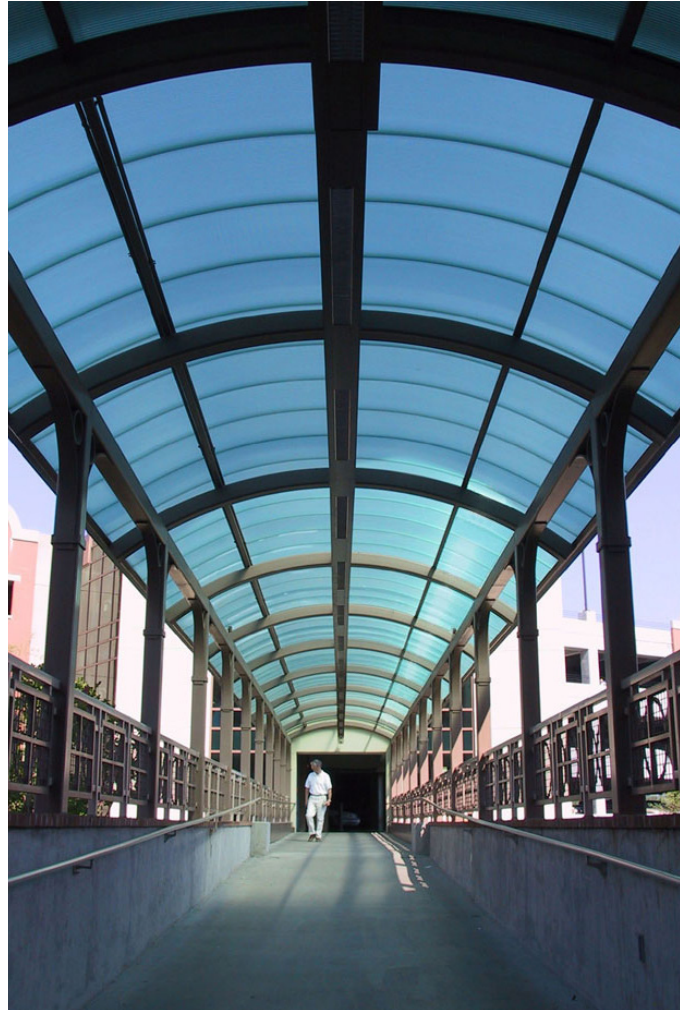

Pre-engineered
to fit your budget



Edward Hynes Elementary School id 31175
New Orleans, LA
Hegedus Architects

photo by LAGNIAPPE PHOTOGRAFX LLC

Clearspan Canopy Design Standards

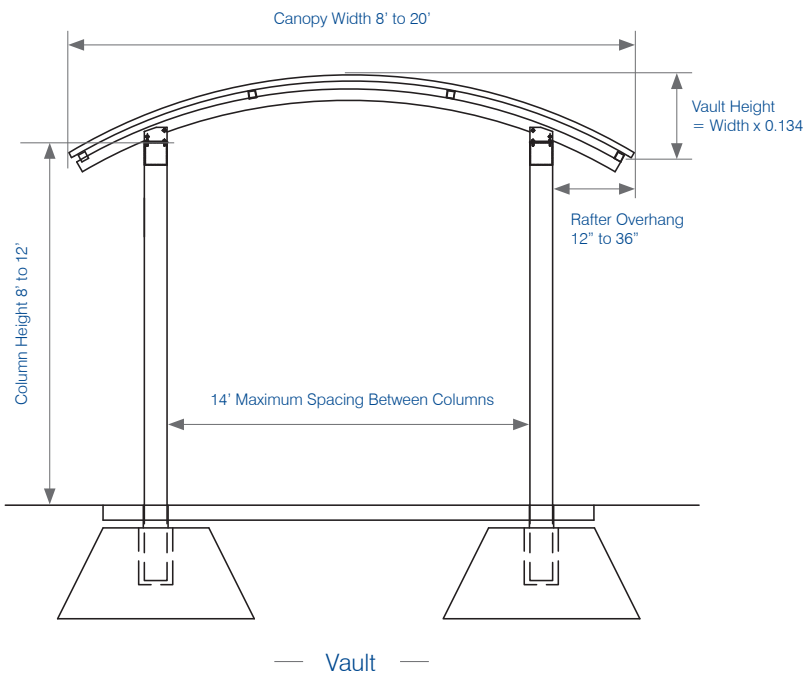

Additional Configurations

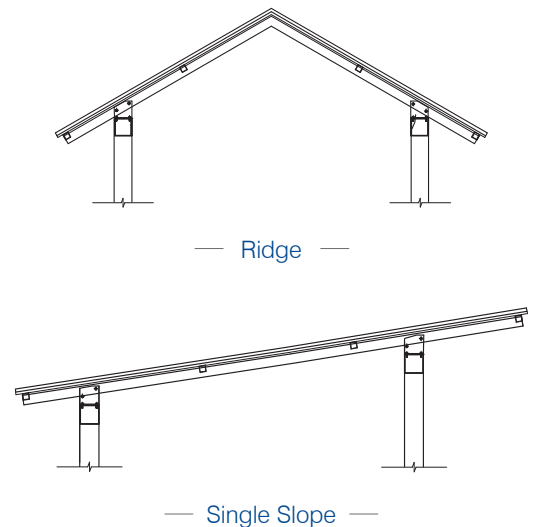



**Kingspan Light + Air
CPI Daylighting**

28662 N. Ballard Drive
Lake Forest, IL 60045 U.S.A.

800.759.6985 847.816.1060

Fax 847.816.0425



To learn more, visit:

cpidaylighting.com

Olympia Regional Learning Academy id 37100
Olympia, WA
TCF Architecture

© 2016 Kingspan Light + Air | CPI Daylighting All rights reserved.

Kingspan Light + Air | CPI Daylighting, Inc. reserves the right to change, discontinue or modify our products, specifications and designs at any time without notice and without incurring obligations. Printed in the U.S.A.